



VLSI Based Image Zooming Application by a Novel Adaptive Edge Enhancement Technique

M.Saranya¹, V.Meenakshi²

PG Student [VLSI], Dept. of ECE, Sona College of Technology, Salem, Tamilnadu, India¹

Assistant professor, Dept. of ECE, Sona College of Technology, Salem, Tamilnadu, India²

ABSTRACT: In this paper, an adaptive edge enhancement technique is proposed for two-dimensional (2-D) image scaling application. The anticipated image scaling algorithm consists of an edge detector, bilinear interpolation and sobel filter. The bilinear interpolation defines the intensity of the scaled pixel with the weighted average of the four nearest neighboring pixels, interpolated images become smooth and loss of edge information. The adaptive edge enhancement technique is used to protect the edge features effectively, to achieve better image quality and to avoid the loss edge information. The sobel filter attempts to reduce the noise, in blurred and distorted edges which is produced by bilinear interpolation. An algebraic manipulation and hardware sharing technique are used to reduce computing resource of the bilinear interpolation. The analysis shows that edges are well preserved and interpolation artifacts (blurring, jaggies) are reduced.

KEYWORDS: Bilinear interpolation, Edge detector, Image zooming, Sobel filter.

I.INTRODUCTION

Image scaling is the process of resizing an image by pixel interpolation, used in computer graphics, medical image processing (such as endoscopy), and digital image devices (such as mobile phones, digital cameras and touch panel computers). An obvious application of image scaling is to scale up images to fit high- definition television (HDTV) and scale down the high-quality pictures or video frames to fit the minimize liquid crystal display panel of the tablet PC.

The image scaling algorithms can be split into two types: polynomial-based and non-polynomial-based methods. The polynomial- based methods are nearest neighbor interpolation, bicubic interpolation, and bilinear interpolation. One of the simplest methods is nearest neighbor interpolation, where each interpolated output pixel is assigned to the value of nearest sample point in the input image. The resulting images of this method are full of blocking and aliasing artifacts. So it is unable to use in high quality imaging applications. The advantage this method are easy to implement and computationally fast, but it does not give good quality of images. Another method is bicubic interpolation; it is based on extended cubic model to scaled images in 2-D regular grid. This algorithm has benefit to produce of high quality images. However, it is computationally expensive due to the complexity in its computation and memory requirements. Bilinear interpolation method which uses linear interpolation can be performed in both horizontal and vertical directions. This method is most widely-used because it reduces the blocking and aliasing effects.

Recently, many popular non-polynomial-based methods have been proposed, such as such as bilateral filter [7], blending kernels [9], adaptive 2-D autoregressive model [11], HVS-directed neural-network [12] and orientation adaptive interpolation [13]. These algorithms are improve image quality and also reduce aliasing and blurring effects but it has high memory requirement ,high complexity, so it is not easy to realized in VLSI technique, low-complexity methods are necessary for VLSI implementation.

One of the resampling methods is winscale algorithm [14]; it uses area coverage of original pixels for measuring new pixels of a scaled image. However, this method requires more time to calculate area coverage. Hardware cost is low but resulting images are undesirable block and blurring effects. A fuzzy image interpolation [10] combined a fuzzy inference system and an image interpolation technique. An adaptive low-cost and high quality image scalar [4], uses a filter combining and hardware sharing technique are used to reduce chip area and memory requirement. A clamp and sharpening spatial filter are used to decrease the blurring effects produced by the bilinear interpolation. The proposed algorithm consists of a sobel filter, edge detector, and bilinear interpolation. The sobel filter and edge detector are used

International Journal of Advanced Research in Electrical, Electronics and Instrumentation Engineering

(An ISO 3297: 2007 Certified Organization)

Vol. 3, Issue 4, April 2014

to enhance the edges of the source images and decrease the blurring effects caused by the bilinear interpolation. The experimental results show that this design improves image quality. The proposed scaling algorithm is designed by Verilog HDL.

II. PROPOSED SCALING ALGORITHM

Fig.1 shows the block diagram of an adaptive edge enhanced scalar architecture. It consists of a sobel filter, edge detector, and bilinear interpolation. Initially, a color image is converted into gray level image using MATLAB. Now gray level image converted into binary image. This binary image is resized and written into a text file. Store the binary image (Text file) into the RAM. Read the Text File from memory Bank. Memory bank provides the input to the sobel filter and edge detector. Further simulation is done by Modelsim.

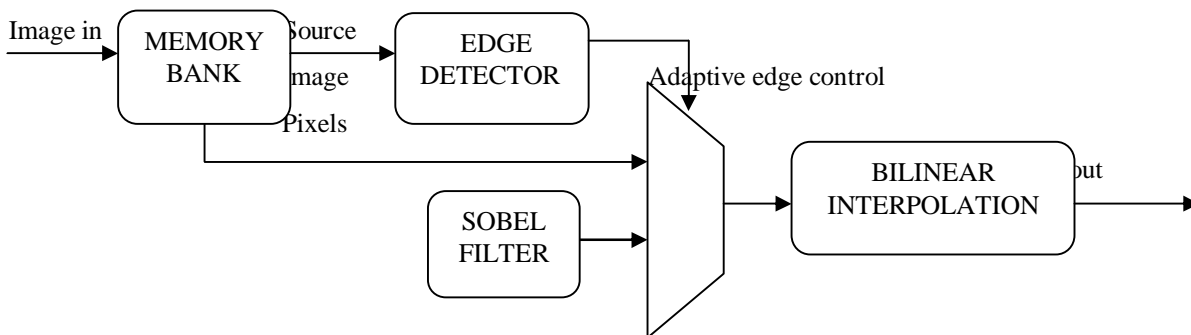

Fig.1. Block diagram of adaptive edge enhanced scalar architecture.

A. Bilinear Interpolation

Bilinear interpolation [1],[2],[4] is a resampling method, it uses the four nearest neighboring pixel value, and then new pixel values are calculated by weighted average of the four nearest-neighbor pixels based on its distance. Linear interpolations are performed in one direction (horizontally) and then one more linear interpolation is performed in the perpendicular direction (vertically).

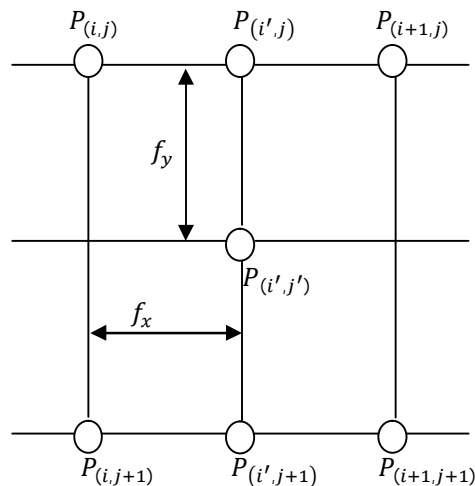

Fig.2 Bilinear Interpolation

The interim pixels are $P_{(i',j)}$, $P_{(i',j+1)}$ are created by linear interpolation in x direction and can be calculated as

$$P_{(i',j)} = (1-f_x) \times P_{(i,j)} + f_x \times P_{(i+1,j)} \quad (1)$$

$$P_{(i',j+1)} = (1-f_x) \times P_{(i,j+1)} + f_x \times P_{(i+1,j+1)} \quad (2)$$

International Journal of Advanced Research in Electrical, Electronics and Instrumentation Engineering

(An ISO 3297: 2007 Certified Organization)

Vol. 3, Issue 4, April 2014

Where f_x is the scale parameter in horizontal direction (x direction). After interpolating in x direction, the values of interim pixels $P_{(i',j)}$, $P_{(i',j+1)}$ are generated. The resulting output pixel $P_{(i',j')}$ can be obtained by linear interpolation in y direction and can be calculated as

$$P_{(i',j')} = [(1-f_x) \times P_{(i,j)} + f_x \times P_{(i+1,j)}] \times (1-f_y) + [(1-f_x) \times P_{(i,j+1)} + f_x \times P_{(i+1,j+1)}] \times f_y. \quad (3)$$

Where f_y is the scale parameter in vertical direction (y direction). The f_x and f_y are zooming ratios of the x and y direction. Bilinear interpolation is more popular in VLSI implementation because of its low complexity. After bilinear interpolation is completed, edges become blurry and give aliasing effect.

B.Edge-Detecting Technique

The edge detecting technique uses a sigmoidal edge detecting method [8]. The interpolated pixel $P_{(k)}$ can be calculated as four closest pixels are $P_{(i-1)}$, $P_{(i)}$, $P_{(i+1)}$, $P_{(i+2)}$ placed at $i-1$, i , $i+1$, $i+2$ respectively as shown in Fig.4.

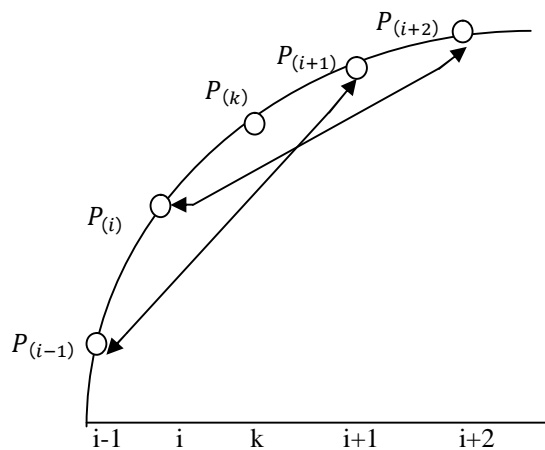

Fig.4. Local characteristics of the data in the neighborhood of k.

An evaluating parameter E to determine the local characteristics of the pixel in the neighborhood of k. It is given as

$$E = |P(i+1) - P(i-1)| - |P(i+2) - P(i)|. \quad (4)$$

1. $E=0$, symmetry of edges on the right side and left side.
2. $E>0$, more homogeneous of edges on the right side.
3. $E<0$, more homogeneous of edges on the left side.

The edge detecting method used to obtain the local characteristics of edges. The interpolated images become smooth and there is a loss of edge information. To protect edge information using an adaptive edge enhancement technique. For example, the edge detector is used to search edges on the left side, if more homogeneous of the left side ($E<0$). To exclude the loss of edge information after bilinear interpolation, right side of two pixels is adaptively enhanced by the Sobel filter.

C. Sobel Filter

Sobel filter is applied to perform edge detection. Sobel filter is used to reduce blurring and aliasing artifacts. It uses two kernels with 3×3 sizes, one estimating the gradient in the x-direction (horizontal) and the other gradient in the y-direction (vertical). These kernels are each convolved with the image.



International Journal of Advanced Research in Electrical, Electronics and Instrumentation Engineering

(An ISO 3297: 2007 Certified Organization)

Vol. 3, Issue 4, April 2014

-1	0	+1
-2	0	+2
-1	0	+1

H_x

+1	+2	+1
0	0	0
-1	-2	-1

H_y

Fig.3. Sobel operator

The algorithm calculates the gradient of the image intensity at each point, and then gives the direction to increase the image intensity at each point from light to dark. Edge areas define strong intensity contrasts which darker or brighter. To measure gradient magnitude is given by

$$|H| = \sqrt{H_x^2 + H_y^2} \quad (3)$$

III. VLSI ARCHITECTURE

Scaling method requires low computational complexity and improves image quality. Fig.5 and Fig.6 shows the architecture of sobel filter, edge detector and bilinear interpolation.

A. Sobel Filter

The Sobel filter is a first order edge detection operator; it uses the two orientations which are 0° and 90° convolution kernels. The filter uses the two masks which are convolved with original image to measure approximations of the gradient. The absolute values of gradient H_x and H_y for pixel $P_{(i+1,j+1)}$ is given by

$$|H_x| = |(P_{(i,j+2)} - P_{(i,j)}) + 2 * (P_{(i+1,j+2)} - P_{(i+1,j)}) + (P_{(i+2,j+2)} - P_{(i+2,j)})| \quad (5)$$

$$|H_y| = |(P_{(i+2,j)} - P_{(i,j)}) + 2 * (P_{(i+1,j+2)} - P_{(i+1,j)}) + (P_{(i+2,j+2)} - P_{(i+2,j)})| \quad (6)$$

The gradient values H_x and H_y are computed according to Eq. 5 and Eq.6. Fig. 5 shows the pipeline architecture of the Sobel filter and edge detector. Upper part of the two-stage shows the pipeline architecture of the Sobel filter. The processing module uses additions, multiplication, and subtractions. In hardware, multiplication is costly. So multiplication is replaced by the shift operation. The architecture for computing both horizontal and vertical gradients is shown in Fig.5.

B. Edge Detector

The local characteristics of edges can be calculated by using Eq.4. Fig.5. shows the lower part of the two stages is edge detector. It consists of one comparator (CMP), three subtractor (|SUB|), and two registers. The |SUB| unit uses two inputs and produces their absolute value of difference. The comparator produce control signal (Ctr_s) for the multiplexer. The control signal (Ctr_s) is based on the evaluating parameter E is greater than 0 (>0), less than (<0), and equal to 0 (=0).

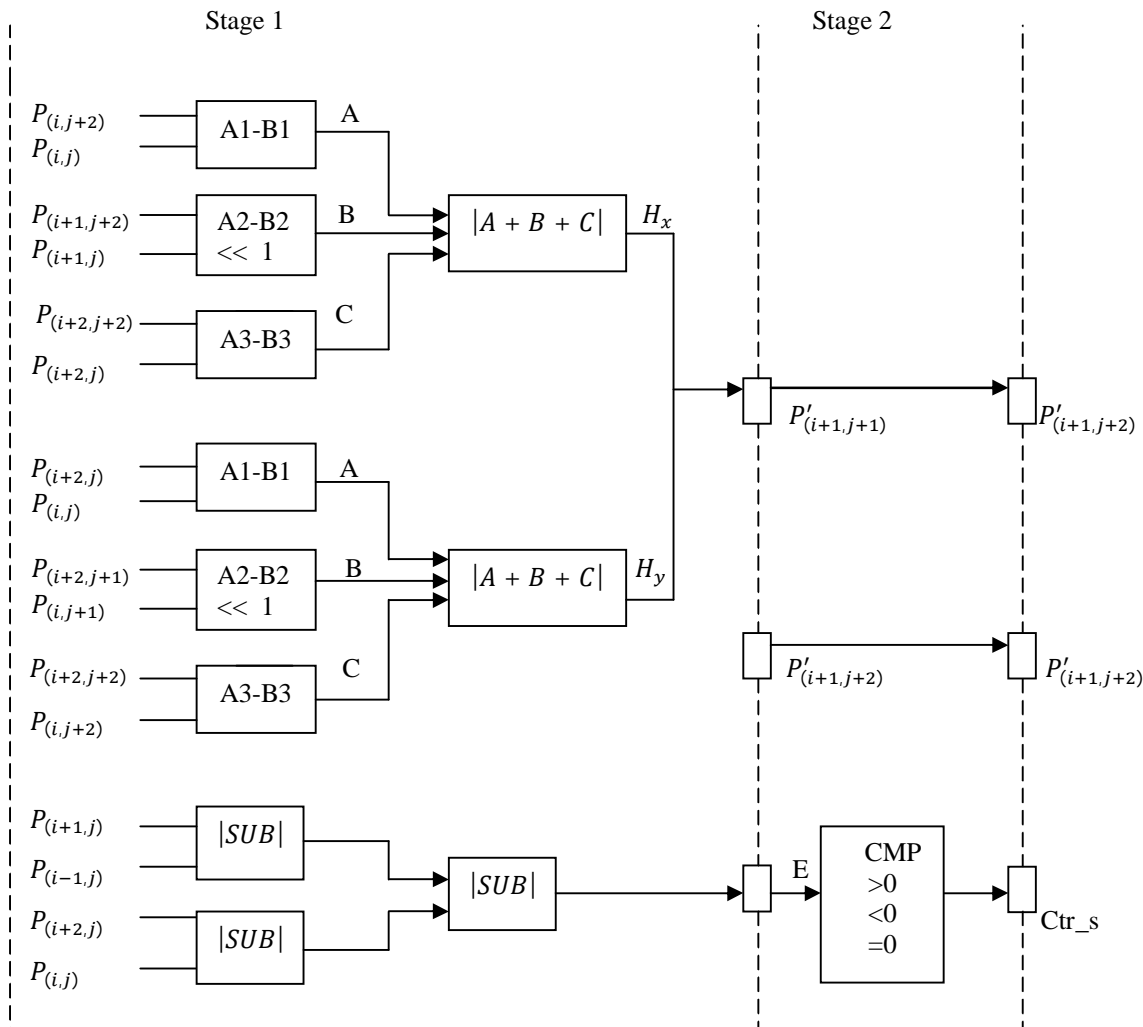

Fig.5. Architecture of sobel filter and edge detector

$$P_{(i',j')} = (1-f_x) \times (1-f_y) \times P_{b(i,j)} + f_x \times (1-f_y) \times P_{b(i+1,j)} + (1-f_x) \times f_y \times P_{b(i,j+1)} + f_x \times f_y \times P_{b(i+1,j+1)} \quad (7)$$

$$= f_x \times [-(1-f_y) \times P_{b(i,j)} + (1-f_y) \times P_{b(i+1,j)} + f_y \times (-P_{b(i,j+1)} + P_{b(i+1,j+1)})] + (1-f_y) \times P_{b(i,j)} + f_y \times P_{b(i,j+1)} \quad (8)$$

$$= f_x \times \{f_y \times [P_{b(i+1,j+1)} - P_{b(i+1,j)}] + P_{b(i+1,j)} - f_y \times (P_{b(i,j+1)} - P_{b(i,j)}) + P_{b(i,j)}\} + f_y \times (P_{b(i,j+1)} - P_{b(i,j)}) + P_{b(i,j)} \quad (9)$$

C. Bilinear Interpolation Circuit

Eq.7 shows arithmetic function of bilinear interpolation. The computing resource cost of bilinear interpolation is further reduced by algebraic manipulation and hardware sharing technique. Eq. (7) through Eq. (8) and Eq. (9) are simplified by algebraic manipulation technique. The stages 3 to 8 in Fig.6 show architecture of bilinear interpolation circuit, in which the six stage pipeline architecture and the two-stage pipelined multipliers. The input values of $P_{(i+1,j+1)}$, $P_{(i+1,j+2)}$, $P_{(i,j+2)}$, $P_{(i,j+1)}$ are obtained from the memory bank, and the values of $P'_{(i+1,j+1)}$, $P'_{(i+1,j+2)}$, $P'_{(i,j+2)}$, $P'_{(i,j+1)}$ are obtained from sobel filter. The edge detector is produce multiplexer control signal (Ctr_s). The multiplexer is adaptively selecting either source values from the memory bank or filtered values from the sobel filter. The f_x and f_y are floating point numbers from 0 to 1.

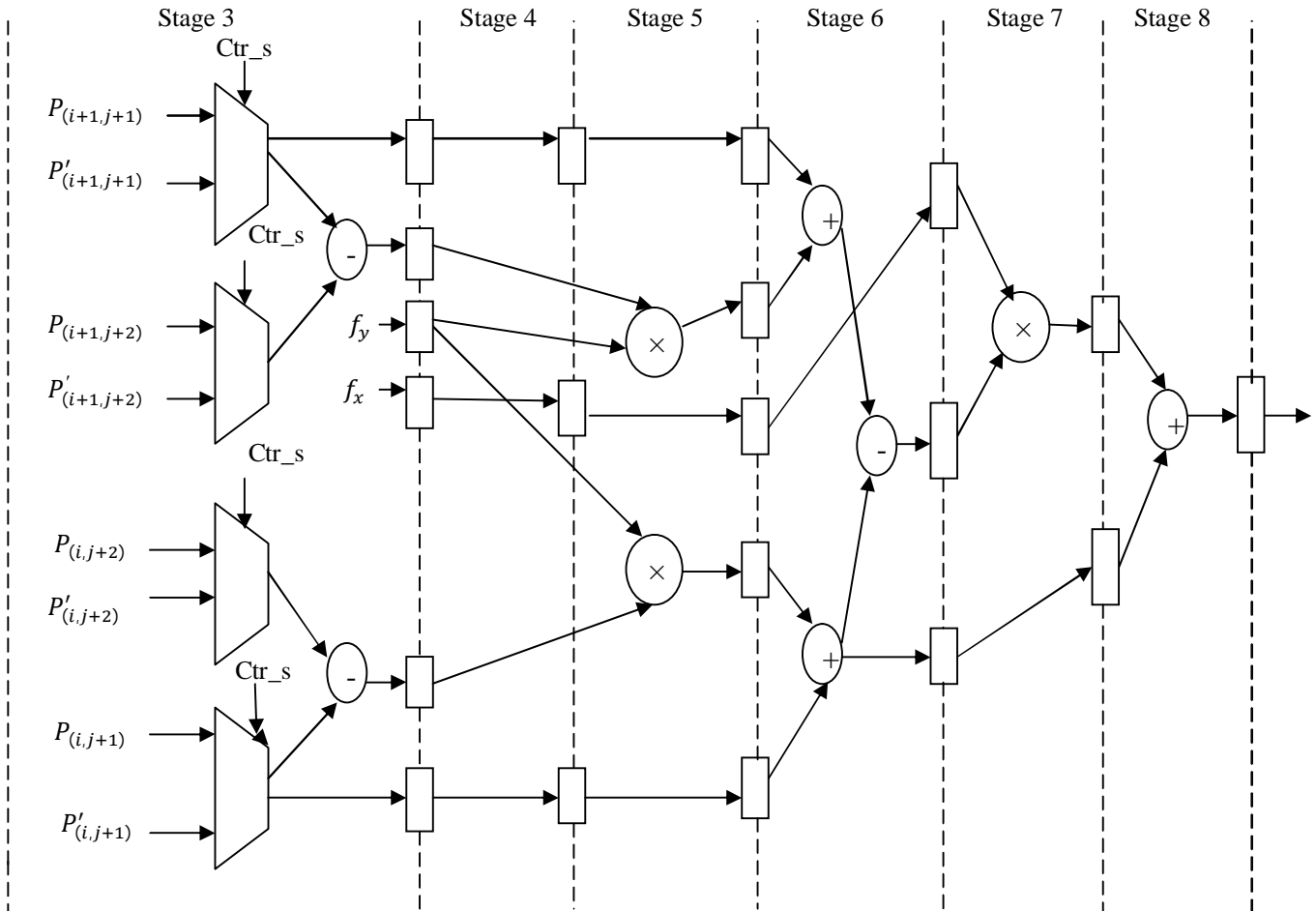

Fig.6. Architecture of the bilinear interpolation.



(a) (b) (c)
Fig.7. Peppers test image scale up from the size of 256×256 to 512×512 (a) original image (b) sharpening spatial filter, edge detector and bilinear interpolation. (c) Sobel filter, edge detector and bilinear interpolation.



International Journal of Advanced Research in Electrical, Electronics and Instrumentation Engineering

(An ISO 3297: 2007 Certified Organization)

Vol. 3, Issue 4, April 2014

IV. EXPERIMENTAL RESULTS

To evaluate the performance of the proposed adaptive edge enhanced scaling algorithm, one test image (256×256) is used in the simulation. First perform up-scaling an image, and then down-scaling an image, finally get the same size of the original image. The Peak-Signal to Noise Ratio (PSNR) is commonly used to measure the quality of a noisy approximation of the $m \times n$ refined image and the original image.

The Mean Squared Error defines the cumulative squared error between the refined image and the original image. The low value of the MSE is considered as low error. The MSE defined as

$$MSE = \sum_{i=1}^x \sum_{j=1}^y \frac{(A_{ij} - B_{ij})^2}{x \cdot y}$$

Where x and y represents the number of rows and columns of the pixels of the original image. The PSNR is defined as

$$PSNR = 10 \log_{10} \left(\frac{R^2}{MSE} \right)$$

The pixels are represented by eight bits per sample, so the maximum value of each pixel (R) is 255. The quality of the scaled image expressed in decibel (dB).

TABLE I

COMPARISON OF PSNR FOR IMAGE ZOOMING ALGORITHMS FROM THE SIZE OF 256×256 TO 512×512

	Sharpening spatial filter, edge detector, bilinear interpolation	Sobel filter, edge detector, bilinear interpolation
Peppers	36.08	42.11

Fig.7 shows the refined Peppers images. By using two methods one Peppers test image is scaled up to double the size and then refined to original size. First method uses a sharpening spatial filter, edge detector, and bilinear interpolation. Second method uses a sobel filter, edge detector, and bilinear interpolation. Table I list the PSNR results of Peppers test image. The experimental results show that the proposed adaptive edge enhanced technique achieves better image quality.

V. CONCLUSION

This paper proposed an adaptive edge enhancement technique for image zooming application, which is easy to implement in VLSI. The sobel filter solved the blurring and aliasing artifacts caused by bilinear interpolation. The adaptive edge enhanced technique is effectively enhanced the edge features of scaled images. An algebraic manipulation and hardware sharing technique in this design greatly reduces the computing resources costs. Comparing results of the proposed method will improve the image quality.

REFERENCES

- [1] Shin-Lun Chen "VLSI Implementation of an Adaptive Edge-Enhanced Image Scalar for Real-Time Multimedia application" IEEE Trans. circuits and systems for video technology, 2013.
- [2] Shin-Lun Chen "VLSI implementation of a low-Cost High-quality Image Scaling Processor", IEEE Trans. circuits and system, vol.60, no.1, Jan.2013
- [3] C. C. Huang, P. Y. Chen, and C. H. Ma, "A novel interpolation chip for real-time multimedia application," IEEE Transaction on Circuits and Systems for Video Technology, Vol. 22, no.10, pp.1512-1525, Oct.2012.



International Journal of Advanced Research in Electrical, Electronics and Instrumentation Engineering

(An ISO 3297: 2007 Certified Organization)

Vol. 3, Issue 4, April 2014

- [4] S. L. Chen, H. Y. Huang, and C. H. Luo, "A low-cost high-quality adaptive scalar for real-time multimedia applications," *IEEE Transaction on Circuits and Systems for Video Technology*, Vol. 21, no. 11, pp. 1600-1611, Nov. 2011.
- [5] H. Kim, Y. Cha and S. Kim, "Curvature interpolation method for image zooming," *IEEE Trans. Image Process.*, vol. 20, no. 7, pp.1895–1903,Jul.2011.
- [6] C. C. Lin, M. H. Sheu, C. Liaw, and H. K. Chiang, "Fast first-order polynomials convolution interpolation for real-time digital image reconstruction," *IEEE Transaction on Circuits and Systems for Video Technology*, Vol. 20, no. 9, pp. 1260-1264, Sep. 2010.
- [7]J. W. Han, J. H. Kim, S. H. Cheon, J. O. Kim and S. J. Ko, "A novel image interpolation method using the bilateral filter," *IEEE Trans. Consumer Electronics*, vol. 56, no. 1, pp. 175-181, Feb. 2010.
- [8] P. Y. Chen, C. Y. Lien and C. P. Lu, "VLSI Implementation of an Edge-Oriented Image Scaling Processor," *IEEE Trans. Very Large Scale Integration Systems*, vol. 17, no. 9, pp. 1275-1284, Sept.2009.
- [9] Luming Liang, "Image Interpolation by Blending Kernels," *IEEE Signal Processing Letters*, vol. 15, no. 1, pp. 805–808, Dec. 2008.
- [10] A. Amanatiadis, I. Andreadis, and K. Konstantinidis, "Design and implementation of a fuzzy area-based image-scaling technique," *IEEE Transaction on Instrumentation and measurement*, Vol. 57, no. 8, pp. 1504-1513, Aug. 2008.
- [11] X.Zhang and X.Wu, "Image interpolation by adaptive 2-D autoregressive modeling and soft-decision estimation", *IEEE trans. Imageprocess*, vol.17, no.6, pp.887-896, Jun.2008.
- [12] C. T. Lin, K. W. Fan, H. C. Pu, S. M. Lu and S. F. Liang, "An HVS-directed neural-network-based image resolution enhancement scheme for image resizing," *IEEE Trans. Fuzzy Systems*, vol. 15, no.4,pp.605-615,Aug.2007.
- [13] Q. Wang and R. K. Ward, "A New Orientation-Adaptive Interpolation Method," *IEEE Trans. Image Process.*, vol. 16, no. 4, pp.889– 900,Apr.2007.
- [14] C. H. Kim, S. M. Seong, J. A. Lee and L. S. Kim, "Winscale : an image-scaling algorithm using an area pixel model", *IEEE trans. Circuit and System for Video Technology*, vol. 13, no. 6, pp. 549-55,Jun.2003.