

Development of Embedded System Based Colorimeter for the Analysis of Copper in Waste Water

Suchita P. Bhangale^{1,2}

R & D Engineer, Pravin Scientific Works, Pune, (HO: Sakri), India¹

Visiting faculty, NowrosjeeWadia College, Pune, India²

ABSTRACT:An embedded system based colorimeter has been developed for the analysis of copper in waste water. The design is based on the ARM-7 LPC-2148 processor. The data convertor section of the processor is interfaced to the photoelectric sensor of the colorimeter. The inbuilt DAC is used for the control of intensity of incident light produced by light source. The monochromatic colored LEDs are used as source of stable light. Similarly the inbuilt ADC is used to measure the potential corresponding to the transmitted light. The transmitted light is detected and converted into potential by the LDR circuit. The instrumental and the experimental errors introduced due to the absorption by cuvette and the reagent respectively were compensated by the software techniques. In addition to above functions, the software performs the operations of calculation of absorptivity coefficient, detection and estimation of concentration of copper. The developed equipment has been successfully used for the analysis of copper in waste water. The software program can be easily modified for the similar study of other analytes.

KEYWORDS:Embedded system, ARM, copper, LED, LDR.

I. INTRODUCTION

The heavy metal like copper plays an important role as toxic element or as nutrient in the biological system. Copper is a part of some enzymes which are required for catalysis of some cellular developments. The redox reaction of copper ions, which allows it to occur in reduced (Cu^{1+}) or anoxidized (Cu^{2+}) state, is important to its catalytic properties [1]. Copper and its compounds are generally used in the treatment of algae in the distributed piped water supply [2]. Trace quantities of copper (II) ion can be found in natural water as waste products from industrial, mining, and agricultural operations. Because low concentrations of copper can be toxic to plant life, many researchers have devised methods of analysis for this metal in water. Heavy metals are generally analyzed by techniques like atomic absorption spectrophotometer [3], total X-ray fluorescent and anodic stripping voltameter.

The variation of the color of a system with changes in concentration of some component forms the basis of colorimetric analysis. A colorimeter can be used to measure any test solution that is itself colored or can be reacted to produce a color. It deals with the color absorbance by the molecules and its analysis. In this technique, determination of elements is based on the absorption of the visible and ultraviolet radiation. The basis of colorimetric method is the simple relationship between absorption of radiation and concentration of colored species in solution. It has high selectivity and used for determining metals in alloys, minerals and complexes [4]. The colorimetric method can be used for the analysis of copper in solution. However, dissolved copper shows light blue color which is not accurately detected by colorimeter. To enhance the color some reagent such as ammonia is generally added to the copper solution. Sensitive and rapid methods for analysis are necessary in the fields like water quality control [5], pollution control, toxicology [6], medical [7,8]. In the past few years, analysts have developed many instrumental techniques. Among these techniques, colorimetric technique occupies a unique position because of its precision, accuracy and rapidity [9,10].

The accuracy and precision of colorimetry depends on monochromaticity and stability of source of light, sensitivity of the detector and signal conditioning circuit. Modern colorimeter is constructed from the electronic devices such as light

International Journal of Innovative Research in Science, Engineering and Technology

(An ISO 3297: 2007 Certified Organization)

Vol. 3, Issue 12, December 2014

emitting diode (LED) [11,12] and LDR. The accuracy of it can be improved by using appropriately designed signal conditioning circuit. Precision of it could be improved with the use of stable source of light, obtained from the constant current driven high intensity LEDs. The automation in measurement and analysis improves rapidly.

In this paper, a low-cost colorimetric method for copper analysis is presented, which combines modern semiconducting devices for the measurement, and advanced microcontroller for the analysis. The system can be used for the automatic analysis of water based samples and has the applications in the area of medical [13].

The rest of the paper is organized as follows. Section II provides a description of electronic circuit, the working of circuit is explained in section III. The experimental work is discussed in section IV, followed by the results and discussions in section V. Section VI gives basic algorithm. Finally, conclusions and some of our thoughts for future directions are presented in section VII.

II. ELECTRONIC CIRCUIT DESIGN AND DESCRIPTION

The electronic circuit designed for the embedded consists of four basic units-LED and LDR circuit, signal processing unit using ARM, user interface and LCD section. These units are shown in the block diagram of colorimeter (see figure 1). The electronic circuit is constructed using the readily available electronic components and its circuit diagram is shown in figure 2. The main units of the circuit are briefly discussed in the next section.

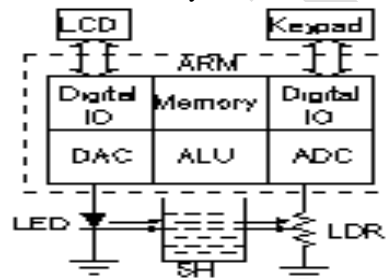

Fig. 1. Block diagram of copper colorimeter.

A. LED - LDR section

LED and LDR are the semiconductor devices used to form the photoelectric sensor of the colorimeter designed using the principle of Beer-Lambert Law [8]. The block diagram shows the LED- LDR section (see figure 1). Each block of the section is discussed in the following section.

1) *Light Source*: The LEDs with different colors are used as source of light [8]. LEDs are constructed from the elements like gallium, arsenic, and phosphorus. The energy gap can be changed by controlling the doping level to yield radiation of different wavelengths. LED has advantages such as monochromatic, high intensity, stable, low cost and locally available.

For the visible range spectroscopy, tungsten filament lamp is an excellent light source. It produces wide range of radiation in the range 400 nm – 700 nm. The small portion of wavelength which is required for absorption by the analyte is selected from a wide range of spectrum with the use of monochromator such as optical filter, prism, or diffraction grating. The design of monochromator is complex, bulky and expensive. The modern type of high intensity LEDs can replace the above light source and monochromator. LEDs require less electric energy and produce monochromatic light. This makes power supply section compact and the instrument portable [8]. The use of LEDs as spectrally selective source of light in photometers was first described by Mims [14]. The normal rectifier diodes, made from silicon or germanium, are opaque and hence none of the light escape. On other hand LED uses semi-transparent material, which permits light to escape outside. By using elements like gallium, arsenic, and phosphorus, the energy gap can be controlled to yield radiation of different colors.

International Journal of Innovative Research in Science, Engineering and Technology

(An ISO 3297: 2007 Certified Organization)

Vol. 3, Issue 12, December 2014

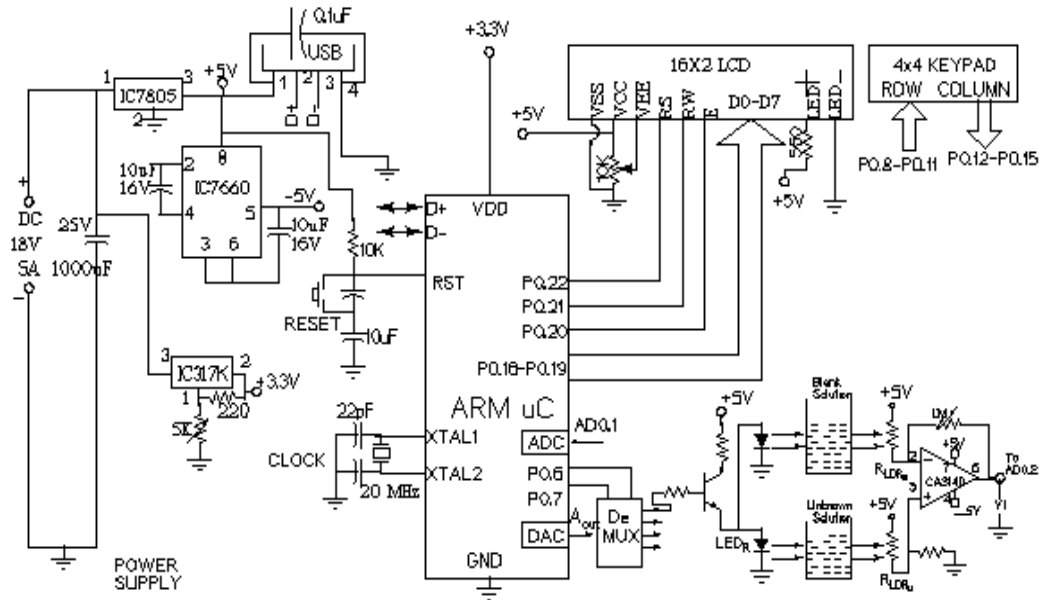

Fig.2. Electronic circuit diagram of microcontroller based copper colorimeter

A typical spectral response of red colored LED is shown in figure 3.

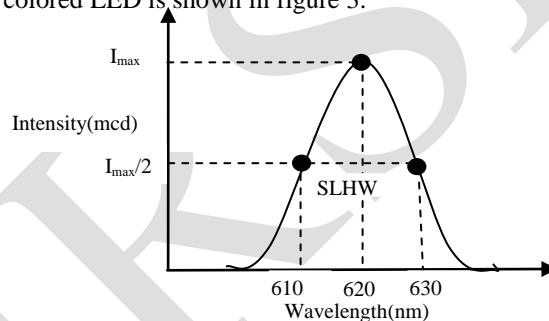

Fig. 3. Spectral response of red colored LED.

The Spectral Line Half-Width (SLHW) is the band width of this curve at 50% intensity. It is of the order of 10 to 50 nm, and it is a measure of monochromaticity of the LED. In the present study, ten watt LEDs of different colors have been used as source of light. The barrier potential of LED is in between 1.2 V to 3.6 V

2) *Sample holder*: The self-absorption of light should be minimum. The most common holders for measuring visible radiation are made from borosilicate glass. LED is fitted on one side of holder and its light is made to pass through the sample placed in holder. The transmitted light passed through the sample, struck the opposite side of the holder, where LDR is mounted.

3) *Detector*: The transmitted light is converted into electric signal by the photoelectric detector. The photoconductive cell made from CdS changes its conductance with light intensity. It is commonly referred as light dependent resistor (LDR). LDR has features such as - broad wavelength range, sensitive to low levels of radiant power, less response time, and produces an electrical signal that can be easily amplified. The resistance of LDR depends on the intensity and wavelength of the light falling on it. The resistance varies typically between 10 MΩ (dark) to about 1 KΩ at 100 Lux. The variation in resistance (R) with intensity (I) is given by the relation [16],

$$\log_{10} (R) = -K \log_{10} (I) + C,$$

Where, K and C are constants which are dependent on wavelength and physical dimensions.

International Journal of Innovative Research in Science, Engineering and Technology

(An ISO 3297: 2007 Certified Organization)

Vol. 3, Issue 12, December 2014

Another commonly used detector is photovoltaic cell. It generates a voltage when its semiconductor surface is illuminated. It is advantageous for its high sensitivity, good stability and no external source of electrical energy is required. It is ideal for low light level applications, where a very high signal to noise ratio is important. The device operates on the principle that irradiation of a p-n junction produce charge carriers known as electron-hole pairs. Once the number of photo-induced carriers exceeds those induced by the thermal process (dark current), the photocurrent is proportional to the intensity of incident radiation [15].

B. Signal conditioner

In present study it is I to V convertor. The light produced by LED is passed through the sample cell. The cell absorbs different amount of light depending on the type and concentration of material in the cell. A photodiode is mounted on the other side of the cell. As the transmitted light struck the photodiode, the electron-hole pairs are formed which leads to an increase in the photocurrent. It is necessary to convert current into voltage, because microcontroller requires input in the form of voltage.

An operational amplifier (OP-AMP) configured as difference amplifier. The ICCA3140 OP-AMP makes a good choice because of its very low input bias current (20 pA) and the input offset voltage (5 mV). The output voltage of converter is given by,

$$V_{out} = \text{Gain} \times (V_u - V_B)$$

Where V_u and V_B are voltages due to unknown and blank solution respectively.

Because some solutions under test may have very strong absorption characteristics, resulting in less transmitted light and small photocurrent. To amplify it to a sufficient level, large value of feedback resistor is required. While at the same time being able to measure the large currents corresponding to the highly diluted solutions. To balance the need of different gain values, variable resistor of value 1 M Ω is used in the feedback [16].

C. Signal processing unit

The signal processing unit has the job of signal acquisition and manipulating it in the form which is required by the readout system. The signal processing unit is ARM 7 LPC 2148 processor[17], which is essentially a 32-bit microcomputer for the operations of data management and modification.

LCD: The microcontroller has the function of analyzing and displaying data on the LCD. It is a character type 16 x 2 LCD which accepts the command and the data in ASCII format. The user interface has been provided by the 4 X 4 keypad. It is constructed from the push to on release to off type key switches. It is interfaced to port 0 of the microcontroller.

D. Power supply section[18] :

It includes three fixed voltage supplies, which are shown in figure 1. Details of them are given below.

+5 V dc power supply: -For microcontrollers, voltage fluctuation is fatal, in such situation to ensure constant voltage; IC 7805 voltage regulator is used. It is a 5V fixed three terminal positive voltage regulator IC. The IC has features such as short circuit protection, thermal shut down, internal current limiting, which makes the IC very rugged. It regulates a steady output of 5 V, if the input voltage is in the range of 7.2V to 35V. Output currents up to 1A can be drawn from the IC provided that there is a proper heat sink.

-5 V dc power supply: -Negative supply voltage is required by OP-AMP. The current requirement is not very demanding, but nevertheless, generating such a -5V supply is relatively expensive. This problem is solved by the voltage convertor IC 7660. With the connection of two 10 μ F capacitors used for charge pump and storage, it performs the complete supply voltage conversion from +5V to -5V.

+3.3V dc power supply: - The ARM 7 LPC 2148 processor requires +3.3 V dc power supply. It is obtained from the adjustable 3 pin regulator LM 317. It requires two external resistors for the adjustment of output voltage. They can be designed by formula,

$$V_0 = 1.25 \times \left(1 + \frac{R_2}{R_1} \right) + I_{adj} \times R_2$$

Where, V_0 = Output voltage, R_1 , R_2 = Resistance values, I_{adj} = current through the ADJUST pin. The current through ADJUST pin is about 50 to 100 μ A. So we may neglect the second term of the above equation. The value of R_1 has to be kept small, about 220 Ω . For 12V output, the R_2 becomes 1892 Ω . In the present work it is a preset of value 5K Ω .

International Journal of Innovative Research in Science, Engineering and Technology

(An ISO 3297: 2007 Certified Organization)

Vol. 3, Issue 12, December 2014

III. CIRCUIT OPERATION

The detailed circuit diagram of the colorimeter is shown in figure 2. In the LED - LDR section of circuit, light from the LED falls on the sample placed in sample holder. The sample absorbs some part of light and the rest is transmitted for to be detected by the LDR placed on the other side of the sample holder. The change in voltage produced by the LDR is converted in to voltage by the operational amplifier. The output of the amplifier is fed inbuilt ADC of ARM processor. This component converts the analog voltage into ten digit binary value. The microcontroller program is written for the ADC operations such as start of conversion, wait till it is converted, when conversion is done then read digital data.

The microcontroller performs the calculations of optical density and concentration. It can be done either with the use of calibration curve or from the equation of line i.e. concentration is the ratio of optical density and slope. In the last section the display of result takes place. The data port of LCD is connected to the port 2 of the microcontroller. Enable, RW, and RS pins of LCD are connected to the Port 1. The schematic diagram and artwork were prepared in PSpice and OrCAD [19] software respectively.

IV. EXPERIMENTAL WORK

All the parts of instrument work together as follows (refer figure 2). LED produces a beam of light with a narrow band of energies. The intensity of the beam, I_0 , for the blank solution is measured by the microcontroller unit. The sample is then placed between the LED and the photodiode. If some of the light is absorbed by the sample, the intensity of the beam reaching the detector, I , will be less than I_0 . The detector compares the two intensities and reports the result as either transmittance (%T) or absorbance (A).

The fraction of I_0 that gets through the sample is called Transmittance (T) is given by,

$$T = \frac{I}{I_0} \dots \dots \dots (1)$$

It is practically difficult to detect absorbance, but it can be calculated from the transmittance.

$$A = -\log_{10} T, A = \log_{10} \frac{1}{T} = \log_{10} \left(\frac{I_0}{I} \right) \dots \dots \dots (2)$$

T is also given by, $T = 10^{-\epsilon lc}$

Where: ϵ = molar absorptivity, l = path length of light beam (cm); c = concentration of absorbing species.

$$\log_{10} T = \log_{10} (10^{-\epsilon lc}) = -\epsilon lc$$

$$A = -\log_{10} T = \epsilon lc \dots \dots \dots (3)$$

In order to achieve the most accurate results of the concentration of colored species in solution, we need to maximize the absorptivity of the species. We must select the wavelength of light from our source that is best absorbed by the molecule. For example, if a solution is blue, it will absorb orange light, and the wavelength of maximum absorbance, λ_{max} , will be 620nm (see Table I). In automated colorimeter it is easy to select the complementary color LED and plotting the absorbance versus the wavelength manually or let the instrument scan through the range automatically, and perform curve fitting. From the plot we can determine the exact wavelength of the complementary color, which is the wavelength of the maximum absorbance (λ_{max}).

The relationship between the absorbance and concentration, given by equation(3), is known as Beer's Law [20]. The absorbance is also called optical density(OD). Since ϵ and l will not change, they can be combined into a new constant, k . Thus, $A = kc$. It can be compared with the equation of a straight line,

$$y = mx + b$$

Where, $y = A$, $x = c$, $m = k$ and $b = 0$, m is slope of the line, and b is they-intercept. Beer's law then states that a plot of absorbance versus concentration will give a straight line passing through the origin. The slope of the line depends upon the constituents of solution, and it is required for the calculation of unknown solution.

There is no direct mathematical relationship between absorbance and concentration. To find the concentration of unknown solution, it is necessary to plot the calibration curve. This curve is called a Beer's Plot [20] which is shown in figure 4. The unknown concentration of colored species in solution can be obtained from the calibration plot.

International Journal of Innovative Research in Science, Engineering and Technology

(An ISO 3297: 2007 Certified Organization)

Vol. 3, Issue 12, December 2014

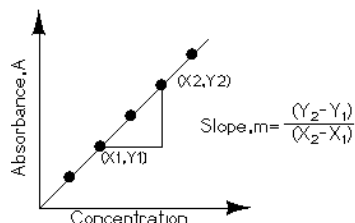

Fig 4: Plot of concentration versus absorbance

V. RESULTS AND DISCUSSION

Five different concentrations of copper sulphate solutions were prepared. Using highest concentration solution of copper sulphate, λ_{max} was determined and it was found to be 625 nm. At this λ_{max} , absorbance of different concentration solutions of copper sulphate as well as unknown concentration solution of copper sulphate are depicted in the Table I. The graph of concentration versus absorbance is shown in figure 5.

Concentration of CuSO ₄ , M	absorbance at λ_{max} = 625 nm
0.048	1.4
0.024	0.73
0.012	0.37
Unknown	0.3
0.006	0.19
0.003	0.1

Table I. Observations of absorbance for the known concentrations of CuSO₄.

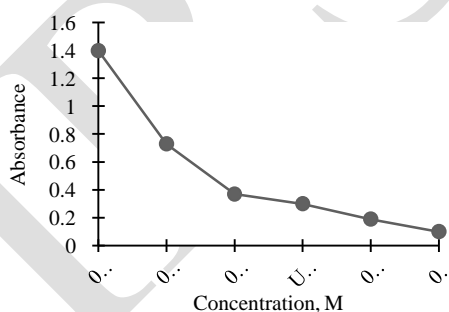

Fig. 5: Calibration curve for finding out concentration of unknown solution.

For a given unknown solution the measured absorbance is 0.30. The concentration of unknown solution is determined from the calibration curve as shown in the above figure. The value of unknown concentration from the curve is found to be 0.01 M.

VI. SOFTWARE

Figure 6 shows the flowchart for the analysis of measured data of copper colorimeter. The steps involved in the measurement of transmitted light and its conversion into absorbance are shown in the flowchart.

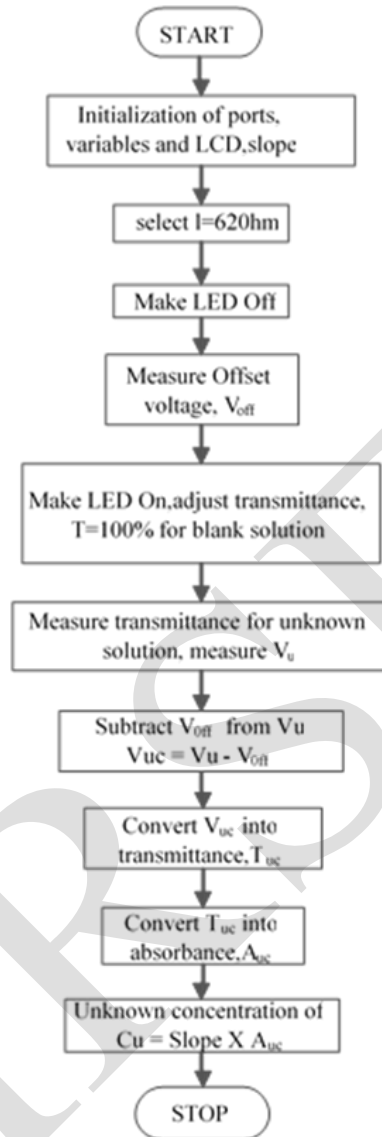

Fig.6.Flow chart of the optical density measurement.

The software program has been developed in the C language. The source code is compiled in Keil[21] IDE, and programmed into ARM -7 LPC 2148 processor with the help of LPC 2000 utility. Soft copy of the program can be obtained freely from the author.

VII. CONCLUSION

The embedded system based colorimeter is an inexpensive instrument that automatically measures the concentration. The ARM-7 LPC-2148 processor makes the instrument compact and durable. The features of the processor such as 10 bit ADC, DAC, RISC instruction set, In system programming, USB communication, simplifies the design of colorimeter. The photoelectric section designed using semiconductor devices LED, LDR and operational amplifier gives accurate analog voltage corresponding to the transmitted light intensity. The voltage produced by programmable DAC unit controls the barrier potential of LED for 0 and 100 % adjustment of transmitted light intensity the black and transparent sample holder respectively. This compensates instrumental as well as experimental errors introduced due to

International Journal of Innovative Research in Science, Engineering and Technology

(An ISO 3297: 2007 Certified Organization)

Vol. 3, Issue 12, December 2014

sample holder and reagent respectively. The gain of operational amplifier can be set for the low and high sensitivity for the concentrated and dilute solutions respectively. The developed software program has been successfully implemented for the determination of characteristics wavelength, absorptivity coefficient and concentration. The developed instrument has been successfully used for the estimation of copper in water solution. Similarly, it can be used for the measurement of concentration of some other metal compounds.

Future scope: The colorimeter will be interfaced to the personal computer. Software program will be developed for the graphical analysis. A comparative study of different set of observations will be carried out by graphical analysis.

Acknowledgment: Author is thankful to the manager of Pravin scientific works, Pune, for providing the laboratory facility.

REFERENCES

- [1] Kim, B.E., Nevitt, T., Thiele, D.J., Mechanisms for copper acquisition, distribution and regulation, Nat. Chem. Biol., Vol. 4(3), pp.176–185, 2008.
- [2] Wehr, J.B., Blamey, F.P.C, Menzies, N.W., “Comparison between methods using Copper, Lanthanum, and colorimetry for the determination of the cation exchange capacity of plant cell walls”, J. Agric. Food Chem., 58(8), pp.4554-4559,2010.
- [3] Alvarez, A.M., Alvarez,J.R.E.,Alvarez,R.P., Heavy metal analysis of rainwaters: A comparison of TXRF and ASV analytical capabilities”, J. RadioanalNucl. Chem, Vol. 273, pp. 427-433, 2007.
- [4] ZolligerH., “Color Chemistry: Syntheses, Properties, and Applications of Organic Dyes and Pigments”, 3rd ed., Wiley-VCH, 2003.
- [5] Brady,J. B., Frantz,J. D., “Microanalytical technique for determination of aluminum in aqueous solutions”, AmericanMineralogist,Vol. 65, pp. 1249-1251, 1980.
- [6] Suzuki,Y.,Endo M., JinJ.,Iwase K., and IwatsukiM., “TristimulusColorimetry Using a Digital Still Camera and Its Application to Determination of iron and Residual Chlorine in Water Samples”,Analytical Sciences, Vol. 22, pp. 411-414, 2006.
- [7] ItodoU., Usman A., SulaimanS. B., ItodoH. U., “Color Matching Estimation of Iron Concentrations in Branded Iron Supplements Marketed in Nigeria”,Advances in Analytical Chemistry, Vol. 2(1), pp. 16-23, 2012.
- [8] Abe A., Yamashita S., Noma A., “Sensitive, direct colorimetric assay for copper in serum”, Clin. Chem. Vol. 35 (4), pp. 552-554, 1989.
- [9] Balas, C., “An Imaging Colorimeter for Noncontact Tissue Color Mapping”,IEEE transactions on biomedical engineering, Vol. 44(6), pp. 468-474, 1997.
- [10] Skoog,A., West,D. M., Holler, F. J. &Crouch,S. R., “Fundamentals ofAnalytical Chemistry”, 8thEdn.,Thomson-Brooks/Cole, 2004.
- [11] Marczenko,Z., “Separation and Spectrophotometric Determination of Elements”, John Wiley and Sons, New York, 1986.
- [12] Brooks,R., Mims III,F. M., “Development of an inexpensive handheld LED-based Sun photometer for the GLOBE program”,Journal of Geophysical research, Vol. 106 (D5), pp.4733-4740, 2001.
- [13] Brown,S. W., Santana,C., and Eppeldauer,G. P., “Development of a Tunable LED-BasedColorimetric Source”,J. Res. Natl. Inst. Stand. Technol.,Vol. 107, pp. 363–371, 2002.
- [14] Mims III,M., “Sun photometer with light- emitting diode as spectrally selective detectors,” Appl. Opt. Vol. 31, pp. 6965-6967, 1992.
- [15] Streetman, B. G., Banerjee, S., “Solid State Electronic Devices”, 6th ed., PHI, New Delhi, 2002.
- [16] Day, R. A., Underwood, A. L., “Quantitative Analysis”, 3rd ed., Englewood Cliffs, NJ: Prentice-Hall, Inc., 1974.
- [17] Furber, S., “ARM System-on –chip Architecture”, 2nd ed., Addison- Wesley, 2000.
- [18] Malvino,A., Bates,D.J., “Principles of Electronics”, 7th ed., Tata-McGraw Hill,2000.
- [19] Rashid,M.H., “Introduction to PSpice and OrCAD for Circuits and Electronics”, Pearson/ Prentice Hall, 2004.
- [20] Skoog,D. A.,Holler,F. J., Crouch,S. R.,“Principles of Instrumental Analysis”,6th ed., Thomson Brooks /Cole, 2007.
- [21] Mazidi, M. A., Mazidi, J. G., “The 8051 Microcontroller and Embedded Systems using Assembly and C”, 2nd ed., Prentice Hall, 2000.

BIOGRAPHY



Mrs. Suchita P. Bhangale has obtained the M.Sc. (Electronic Sc.) degree in year 2004 from NMU, Jalgaon. She is working as R & D Engineer at Pravin Scientific Works, Pune (HO: Sakri). She is also working as visiting faculty of Electronics at NowrosjeeWadia College, Pune. She has published more than five research papers in the international journals. Her research subject is Analytical Instrumentation.