



# **Design and Simulation Studies of D-STATCOM for Mitigating Voltage Sag Problem by Using Fuzzy Inference System, and Proportional Integral based on controlled application**

Hamza Jaber Mohamed<sup>1</sup>, Mohamed Ali Abdulsalam<sup>2</sup>, Fathi A Mansur<sup>3</sup>, Miftahul Anwar<sup>4</sup>,  
Muhammad Nizam<sup>5</sup>

P.G.Student, Department of Mechanical Engineering, SebelasMaretUniversity, Surakarta, Indonesia<sup>1</sup>

P.G.Student, Department of Mechanical Engineering, SebelasMaretUniversity, Surakarta, Indonesia<sup>2</sup>

P.G.Student, Department of Mechanical Engineering, Sebelas Maret University, Surakarta, Indonesia<sup>3</sup>

Associate Professor, Department of Mechanical Engineering, Sebelas Maret University, Surakarta, Indonesia<sup>4</sup>

Professor, Department of Mechanical Engineering, Sebelas Maret University, Surakarta, Indonesia<sup>5</sup>

**ABSTRACT** - Over the recent period of time power quality problems have been remarked as a buzzing issue with regard to promoting delicate and miniature electronic devices where Voltage sag problem is the most frequently occurring and detrimental power quality problems. Thus, the purpose of this study was to assuage voltage sag problem using proposed Distribution Static Compensator (D-STATCOM) along two controlling methods namely FIS and PI. Being a part of implementation, two control methods such as Proportional Integral (PI) and Fuzzy Inference (FIS) were introduced to ascertain the injection of current and comparison of timely responses. The results showed that FIS and PI were capable to recover the voltage sag by 98.20%, 96.15%, 93.55% and 95.10 %, 94.45%, 90 % at single-phase, two-phase, and three-phase, respectively, while, without D-STATCOM it was only 24% at three phases. In the end, the newly improved D-STATCOM power distribution system was accomplished as a proficient compensator for the reactive power requirement of the load. Furthermore, it is to be anticipated that in future this proposed distribution system device will be recognized as a new effective customer power device to mollify voltage sag problem commercially.

**KEYWORDS** – Distribution Static Compensator (D-STATCOM), Fuzzy Inference Systems (FIS), Proportional Integral (PI), Voltage Sag, MATLAB.

## **I. INTRODUCTION**

Power quality is one of major concern in the present era. It has become important, especially, with the introduction of sophisticated devices, whose performance is very sensitive to the quality of power supply. The power quality problem is an occurrence manifested as a nonstandard voltage, current or frequency that results in a failure of end use equipments [1].

Power quality problems comprise a wide range of disturbances such as voltage sags/ swells, flicker, harmonics, distortion, impulse, transient and interruptions. Among this problem, voltage sags is the most commonly occurring problems in terms of power quality problems. The IEC electro technical vocabulary, IEC 60050- 604, 1998 defines a voltage sag as any “sudden reduction of the voltage at a point in the electrical system, followed by voltage recovery after a short period of time, from half a cycle to a few seconds”. Likewise, in more explicitly, A sag, as defined by

# International Journal of Advanced Research in Electrical, Electronics and Instrumentation Engineering

(An ISO 3297: 2007 Certified Organization)

Vol. 3, Issue 8, August 2014

IEEE Standard 1159, IEEE Recommended Practice for Monitoring Electric Power Quality, is “a decrease in RMS voltage or current at the power frequency for durations from 0.5 cycles to 1 minute, reported as the remaining voltage”. Typical values are between 0.1 p.u. and 0.9 p.u. Typical fault clearing times range from three to thirty cycles depending on the fault current magnitude and the type of over current detection and interruption. Actually, Voltage sags are appearing due to faults, motor starting, and transformer energizing.

There are different ways to mitigate power quality problems in transmission and distribution systems. Among these, the D-STATCOM is one of the most effective devices. A Distribution Static Compensator (D-STATCOM) is the most efficient and effective modern custom power device used in power distribution networks. Its appeal includes lower cost, smaller size, and its fast dynamic response to the disturbance. [2]. The importance of this paper is to resolve voltage sag problem manifested in voltage/current or frequency deviations that result in failure of customer equipment. and to present the model of the custom power device, namely, D-STATCOM and its control application to mitigate voltage sag, the proposed D-STATCOM model was developed using MATLAB/Simulink environment, Simulation results were presented to demonstrate the voltage sag of the D-STATCOM. [7].

## II. BASIC THEORY

### A. D-STATCOM

A distribution static compensator (D-STATCOM) is the most efficient and effective modern custom power device used in power distribution system. Its appeal includes lower cost, smaller size, and its fast dynamic response to the disturbance. D-STATCOM consists of a voltage source converter (VSC), a DC energy storage device (ESD), a coupling transformer connected in shunt to the distribution system through a coupling transformer. The VSC converts the DC voltage across the storage device into a set of three phase AC output voltages. These voltages are in phase and coupled with the AC system through the reluctance of the coupling transformer. Suitable adjustment of the phase and magnitude of the D-STATCOM output voltages allows effective control of active and reactive power exchanges between the D-STATCOM and the AC system. Such configuration allows the device to absorb or generate controllable active and reactive power. As shown in figure 1[3].

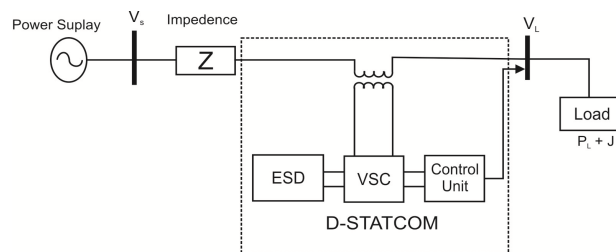

Figure 1 Schematic Representation of D-STATCOM [3].

### B. PROPORTIONAL INTEGRATIVE (PI) CONTROLLER

The aim of the control A proportional integrative (PI) scheme is to maintain constant voltage magnitude at the point where a sensitive load is connected, under system disturbances. The control system only measures the r.m.s voltage at the load point, i.e., no reactive power measurements are required. The VSC switching strategy is based on a sinusoidal PWM technique which offers simplicity and good response. Since custom power is a relatively low-power application, PWM methods offer a more flexible option than the Fundamental Frequency Switching (FFS) methods favoured in flexible alternating Current transmission systems (FACTS) applications. Besides, high switching frequencies can be used to improve on the efficiency of the converter, without incurring significant switching losses. The controller input is an error signal obtained from the reference voltage and the value rms of the terminal voltage measured. Such error is processed by a PI controller the output is the angle  $\delta$ , which is provided to the PWM signal generator. It is important to note that in this case, indirectly controlled converter, there is active and reactive power exchange with the network simultaneously: an error signal is obtained by comparing the reference voltage with the rms voltage measured at the

# International Journal of Advanced Research in Electrical, Electronics and Instrumentation Engineering

(An ISO 3297: 2007 Certified Organization)

Vol. 3, Issue 8, August 2014

load point. The PI controller process the error signal generates the required angle to drive the error to zero, i.e., the load rms voltage is brought back to the reference voltage.As shown in figure 2 [4].

PI Controller (proportional-integral controller) is a close loop controller which drives the plant to be controlled with a weighted sum of error and integral that value. PI Controller has the benefit of Steady-state error to be zero for a step input.

$$\text{Output of comparator} = V_{ref} - V_{in} \tag{1}$$

Where,

$V_{ref}$ : Equal 1 per unit voltage reference.

$V_{in}$ : Voltage in 1 per unit at the load terminals.

PI controller input is an actuating signal which is the difference between the  $V_{ref}$  and  $V_{in}$  Output of the controller block the angles. The angle provides to PWM signal generator to obtain desired firing sequence. Fig. 2 is shown medal of PI controller in MATLAB.

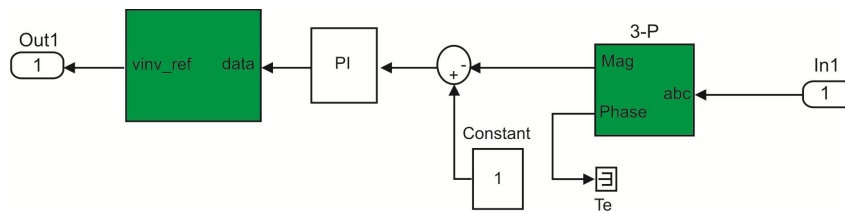

Figure 2 Simulink Model of PI Controller.

## C. FUZZY INFERENCE SYSTEM (FIS)

Fuzzy inference systems (FIS) are one of the most famous applications of fuzzy logic and fuzzy set theory. They can be helpful to achieve classification tasks, offline process simulation and diagnosis, online decision support tools and process control. The strength of FIS relies on their twofold identity. On the one hand, they are able to handle linguistic concepts. On the other hand, they are universal approximates able to perform nonlinear mappings between inputs and outputs. These two characteristics have been used to design two kinds of FIS. The first kind of FIS to appear focused on the ability of fuzzy logic to model natural language. These FIS contain fuzzy rules built from expert knowledge and they are called fuzzy expert systems or fuzzy controllers, depending on their final use. Prior to FIS, expert knowledge was already used to build expert systems for simulation purposes. These expert systems were based on classical Boolean logic and were not well suited to managing the progressiveness in the underlying process phenomena. Fuzzy logic allows grading rules to be introduced into expert knowledge based simulators. It also points out the limitations of human knowledge, particularly the difficulties in formalizing interactions in complex processes [5]. Fuzzy inference is the process of formulating the mapping from a given input to an output using fuzzy logic. The mapping, then provides a basis from which decisions can be made, or patterns discerned. [6]. The fuzzy inference system is shown in Figure 3.

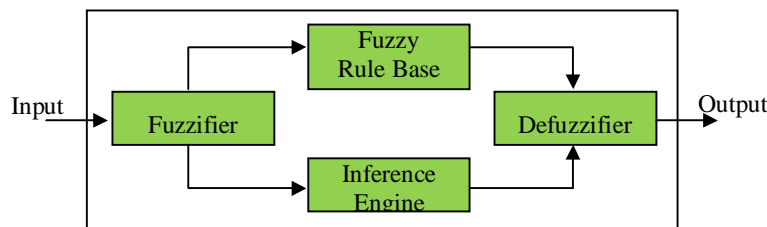

Figure 3 Fuzzy Inference System [6]

Error Calculation The error is calculated from the difference between supply voltage data and the reference voltage data. The error rate is the rate of change of error. The error and error rate are defined as:

$$\text{Error} = V_{ref} - V_S \tag{2}$$

# International Journal of Advanced Research in Electrical, Electronics and Instrumentation Engineering

(An ISO 3297: 2007 Certified Organization)

Vol. 3, Issue 8, August 2014

$$\text{Error rate} = \text{error}(n) - \text{error}(n-1) \quad (3)$$

Where is:

Vref is voltage References.

VSis voltage Source.

Error is Error supply.

Error rate is Error rate supply.

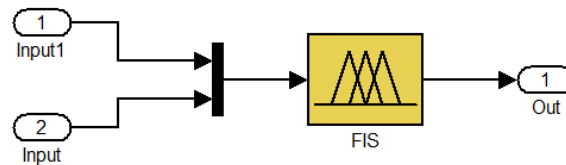

Figure 4(FLC) Scheme

### III. METHODS

The aim of the control system is to maintain voltage magnitude at the point where a sensitive load is connected under system disturbances. Voltage sags is created at the load terminals via a three-phase fault. The above voltage problems are sensed separately and passed through the sequence Analyzer. The control system of the general configuration typically consists of a voltage correction method which determines the reference voltage injected by D-STATCOM.

FIS has two inputs and one output, the input consisting of 5 members and output fuzzy consists of 5 members. Where the input variables in the range [-5 5], while the output variable in the range [-10 10].

A process for constructing a FIS can be summarized as follows:

- I. Choose a specific type of FIS (Mamdani or Sugeno)
- II. Select relevant input-output variables
- III. Determine the number of linguisticTerms associated with each input-output variable (determine the membership function for each linguistic term)
- IV. Design a collection of fuzzy if-then rules
- V. Choose the defuzzification method.

Fuzzification is an important concept in the fuzzy logic theory. Fuzzification is the process where the crisp quantities are converted to fuzzy. Thus Fuzzification process may involve assigning membership values for the given crisp quantities. This unit transforms the non-fuzzy (numeric) input variable measurements into the fuzzy set (linguistic) variable that is a clearly defined boundary, without a crisp (answer). In this simulation study, the error and error rate are defined by linguistic variables such as negative big (NB), negative medium (NM), negative small (NM), zero (Z), positive small (PS), positive medium (PM) and positive big (PB) characterized by membership functions given in this Figure.

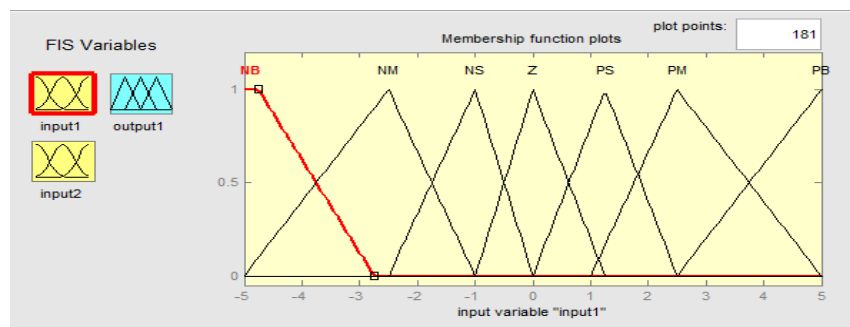

Figure 5 Input1 (Error) membership function of FIS.

# International Journal of Advanced Research in Electrical, Electronics and Instrumentation Engineering

(An ISO 3297: 2007 Certified Organization)

Vol. 3, Issue 8, August 2014

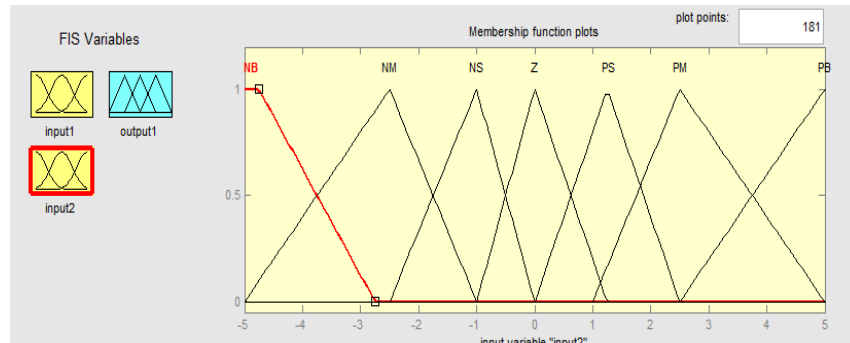

Figure 6 Input2 (Delta-error) membership function of FIS.

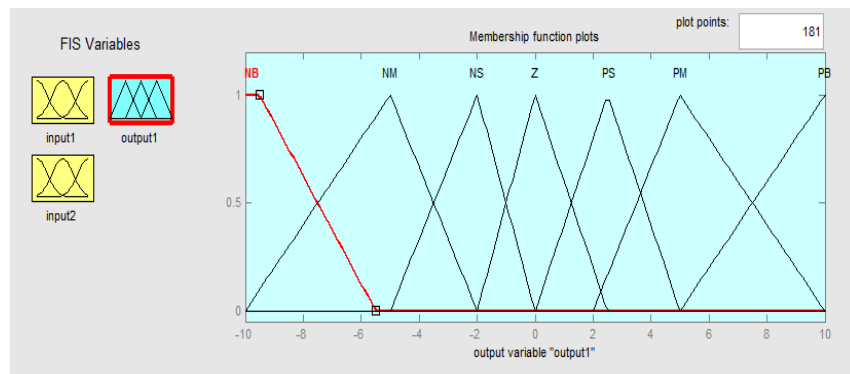

Figure 7 output membership function of FIS.

There are 49 rules for FIS. The output membership function for each rule is given by the Min (minimum) operator. The Max operator is used to get the combined FIS output from the set of outputs of Min operator. The output is produced by the fuzzy sets and fuzzy logic operations by evaluating all the rules.

Table 1 Fuzzy Rules

Error Delta-error	NB	NM	NS	Z	PS	PM	PB
NB	NB	NB	NB	NM	NM	NS	Z
NM	NB	NB	NM	NM	NS	Z	PS
NS	NB	NM	NM	NS	Z	PS	PM
Z	NM	NM	NS	Z	PS	PM	PM
PS	NM	NS	Z	PS	PM	PM	PB
PM	NS	Z	PS	PM	PM	PB	PB
PB	Z	PS	PM	PM	PB	PB	PB

## IV. SIMULATION AND RESULT

To enhance the performance of the distribution system, D-STATCOM is connected to the distribution system. D-STATCOM is designed using MATLAB, Simulink version R2012b. As shown in figure8

# International Journal of Advanced Research in Electrical, Electronics and Instrumentation Engineering

(An ISO 3297: 2007 Certified Organization)

Vol. 3, Issue 8, August 2014

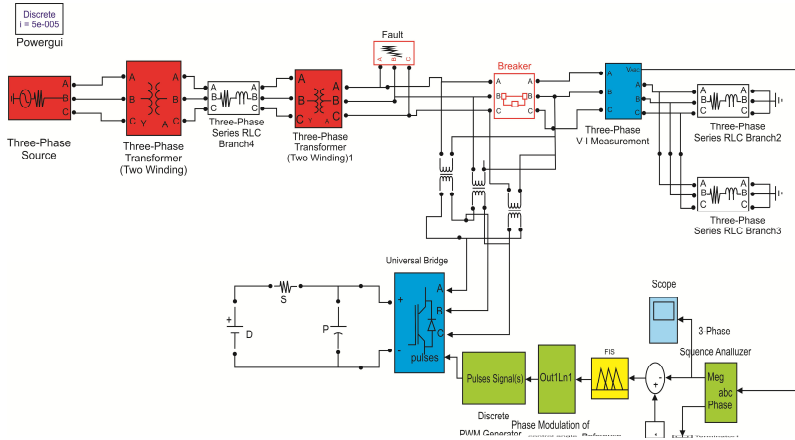

Figure 8 Simulink Model For D-STATCOM

The system was designed based on D-STATCOM as a controlled reactive source, which includes a Voltage Source Converter (VSC) and a DC link capacitor connected in shunt, capable of generating and/or absorbing reactive power. Indeed, it was used to compensate the power system disturbances such as voltage sags. Practically, the Table 2 shown parameters of system.

Table 2 Parameters of MATLAB Simulink

1	Voltage Source	230Kv
2	Frequency	50Hz
3	Line impedance	0.001Ω, 0.005H
4	DC voltage	5000V
5	Capacitor	750μF
6	Load1	0.5MW,0.2MVAr

The figure 9 below illustrates the comparison of the findings of single fault scenario of two controlling methods such as PI controller and FIS uses D-STATCOM. Here, the X-axis and Y-axis are represented by time and voltage (p.u.), respectively, and the red and black colour indicates the result of PI and FIS, respectively.

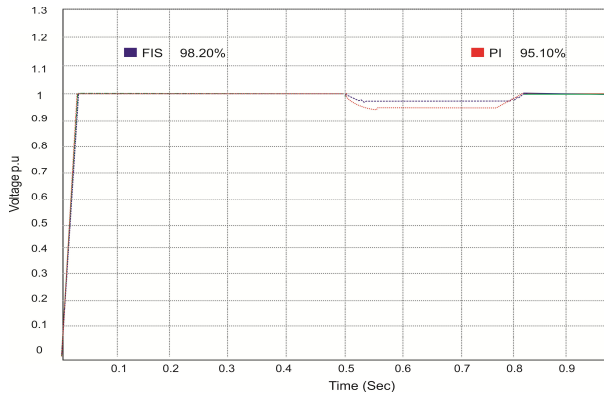

Figure 9 Single phase fault scenario Result of comparison uses the PI Controller and FIS.

From above figure, it can be seen that although both of the methods were able to demonstrate the significant percentage of mitigating the voltage sag, however, the compensation rate of voltage sag was higher at FIS compare to PI method.



## International Journal of Advanced Research in Electrical, Electronics and Instrumentation Engineering

(An ISO 3297: 2007 Certified Organization)

Vol. 3, Issue 8, August 2014

The percentage of recovering voltage sag by FIS was 98.20%, whereas, the PI showed the 95.10% voltage sag compensation at the same experimental condition.

In case of time respond both the method followed the same pathway. Since the beginning to 0.03 second the voltage per unit increased steeply, o voltage per unit to 1 voltage per unit , and then it remained constant from 0.03 to 0.5 second. Afterwards, the voltage sag was generated which sustained upto 0.8 second. Within this time the two controlling methods showed their performance to mitigate the voltage sag. Having recovered the voltage sag problem, both the method ran the at same voltage rate as like as before voltage sag problem.

The figure 10 below depicts the comparison of the results of two fault scenario of two controlling methods, namelythe PI controller and FIS uses D-STATCOM. Here, the X-axis and Y-axis are represented by time and voltage (p.u.), respectively and the read and black color indicate the result of PI and FIS, respectively .

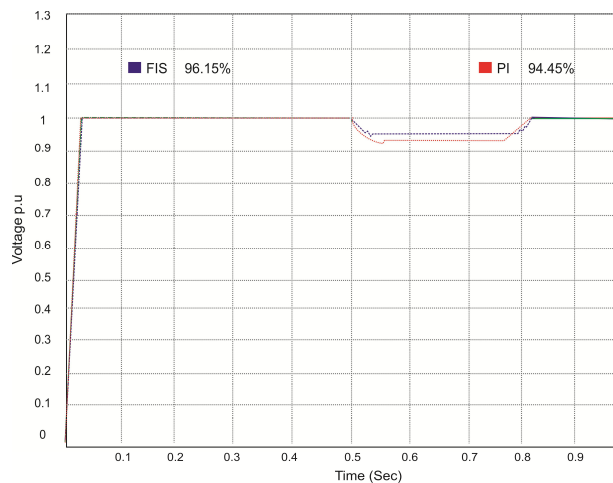

Figure: 10 Two phase fault scenario Result of comparison use the PI Controller and FIS

From above figure, it is clear that the recovery rate of voltage sag compared upper at FIS to PI method, though both of the methods were able to demonstrate the notable percentage of mitigating the voltage sag,. The percentage of recovering voltage sag by FIS was 96.15 % , while, the PI revealed the 94.15 % voltage sag compensation at the same experimental condition.

In case of time respond both the method crossed the same pathway. From the beginning to 0.03 second the voltage per unit grew steeply, o voltage per unit to 1 voltage per unit, and then it remained unchanged from 0.03 to 0.5 second. Afterwards, the voltage sag was generated which sustained up to 0.8 second. Within this time the two controlling methods demonstrated their performance to assuage the voltage sag. Having compensated the voltage sag problem, both the method followed the at same voltage rate as same as before voltage sags problem.

The figure 10 below shows the comparison of the results of three fault scenario of two controlling methods, namely the PI controller and FIS uses D-STATCOM, and the result of mitigating the voltage sag without D-STATCOM. Here, the X-axis and Y-axis are represented by time and voltage (p.u.), respectively, and the red and black colour indicates the result of PI and FIS, respectively.



# International Journal of Advanced Research in Electrical, Electronics and Instrumentation Engineering

(An ISO 3297: 2007 Certified Organization)

Vol. 3, Issue 8, August 2014

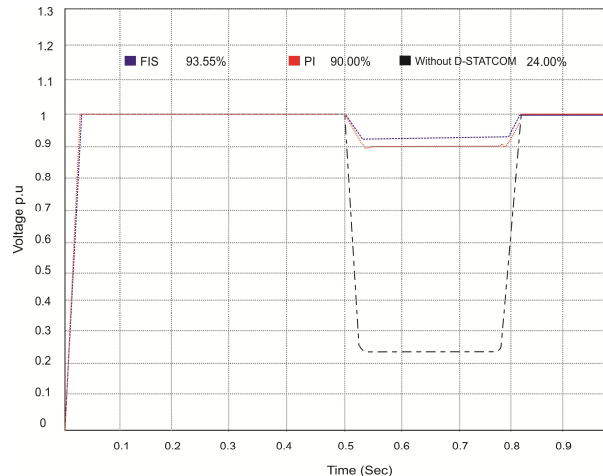

Figure 11 Three phase fault scenario result of comparison uses the PI Controller and FIS.

From above figure, it is obvious that FIS and PI controller method using D-STATCOM countervailed voltage sag problem 93.55% and PI 90 %, on the other hand, without D-STATCOM it was obtained only 24%.

In terms of time respond all the methods raced the almost same pace. From the beginning to 0.03 second the voltage per unit rose steeply, no voltage per unit to 1 volts per unit, and then it did not change from 0.03 to 0.5 second. Afterwards, the voltage sag was generated which sustained up to 0.8 second. Within this time all the two controlling methods demonstrated their performance to assuage the voltage sag. Having extricated the voltage sag problem, all the method carried out the at a similar voltage rate as before voltage sags problem.

## V. CONCLUSION

To sum up, it can be attained that in terms of all phases such as single, two and three phase scenario results, FIS method integrated with D- STATCOM has been substantiated as a better method than the PI controller method mediated with D-STATCOM, while, in terms of three phases without D-STATCOM, percentage of compensating voltage sag was merely 24%. As a result, the FIS controlling method integrated with D- STATCOM can be conferred for usage widely for the mitigation of voltage sag problem. Furthermore, it is to be deduced that in future this proposed distribution system device will be established as a proficient customer power device commercially. In a nutshell, it can be enunciated that voltage sag is one the most harmful problems in terms of power quality problems. Thus, a promising device (D-STATCOM) using two controlling methods such as Fuzzy Inference Systems (FIS) and Proportional Integral (PI) were applied to compensate the voltage sag and fault detection. Subsequently, the results demonstrated that FIS was better than PI by executing the controlled reactive source infused accurate electric flow and restored quickly concerning to any incongruity in the distribution system and recovered to voltage sag 98.50%, 96.15%, 93.55% at single, two and three phase system respectively. Furthermore, it is to be deduced that in future this proposed distribution system device will be established as a proficient customer power device commercially.

## REFERENCES

- [1] Deshmukh, S. M and Dewani, B. "Overview of Dynamic Voltage Restorer (DVR) for Power Quality Improvement." International Journal of Engineering Research and Applications (IJERA), pp.1372-1377, 2012
- [2] Kadam, A. Dhamdhare, S and Bankar, D. "Application of DSTATCOM for Improvement of Power Quality using MATLAB Simulation." International Journal of Science and Modern Engineering. Vol. 1, pp.9-13.ISSN: 2319-6386, 2012.
- [3] Rambabu, E. Praveena, E and Kishore, P. "Mitigation of Harmonics in Distribution System Using D-STATCOM." International Journal of Scientific & Engineering Research Vol. 2, pp.1-5, 2011.
- [4] Patil, D. R., and Madhale, K. "Design and Simulation Studies of D-STATCOM for Voltage Sag, Swell Mitigation." IRNet Transactions on Electrical and Electronics Engineering: pp. 97-103, 2007.
- [5] Sumalatha, V. Ramani, K and Lakshmi, K. V. "Fuzzy Inference System to Control PC Power Failures." International Journal of Computer Applications, Vol. 28, pp.10-17, 2011.





ISSN (Print) : 2320 – 3765  
ISSN (Online): 2278 – 8875

# International Journal of Advanced Research in Electrical, Electronics and Instrumentation Engineering

(An ISO 3297: 2007 Certified Organization)

Vol. 3, Issue 8, August 2014

[6] Ramnath, B. Vijaya, C. Elanchezhian, and Kesavan, R "Suitability assessment of lean kitting assembly through fuzzy based simulation model." International Journal of Computer Applications, Vol. 4, pp. 25-31, 2010.

[7] Hussain, K., and Praveen, J. "Voltage Sag Mitigation Using Distribution Static Compensator System." International Journal of Engineering and Technology 2.5, 2012.

## BIOGRAPHY



**Hamza Jaber Mohamed** was born in 09-07-1987, Algatron-Libya. He is currently working toward the MSc degree in Sebelas Maret University, Central Java, Indonesia. His research interest includes Power Quality, Control Systems, Simulation and Renewable energy.



**Mohamed Ali Abdulsalam** was born in 08-02-1983, Alshati-Libya. He is currently working toward the MSc degree in Sebelas Maret University, Central Java, Indonesia. His research interest includes Power Quality, Control Systems, Simulation and Renewable energy.



**Fathi A Mansur** was born in 27-02-1985, Agdabia-Libya. He is currently working toward the MSc degree in Sebelas Maret University, Central Java, Indonesia. His research interest includes Power Quality, Control Systems, Simulation and Renewable energy.



**Miftahul Anwar, Ph.D** MECHANICAL Engineering Department, Faculty of Engineering, Sebelas Maret University, Surakarta, Indonesia. (Mobile)+62271632112



**Prof. Muhammad Nizam. M. T. Ph.D** MIEEEE., IPM. Member of University Sensate / Head of control unit UNS Ex. Power System. Power Quality. Energy Management System.